

USER MANUAL

5KWH

Advanced Low Voltage LiFePO4 Battery



End User Documentation
Rev 2.0

February-01-2025



WARNING: Explosion, Electrocution, Or Fire Hazard

- A battery can present a risk of electric shock, burns from high short circuit current, fire, or explosion.
- Observe proper precautions.
- Ensure the cables are properly sized.
- Ensure clearance requirements are strictly enforced around the batteries.
- Ensure the area around the batteries is well ventilated and clean of debris.
- Always use insulated tools. Avoid dropping tools onto batteries or other electrical parts.
- Never charge a frozen battery unless optional heater parts inside.
- If a battery must be removed, always remove the grounded terminal from the battery first. Make sure all devices are disconnected.
- All devices must be disconnected when updating the BMS software.
- DO NOT short the battery terminals.
- DO NOT incinerate, crush, or disassemble.
- DO NOT reverse connect (polarity) battery to the charger.
- DO NOT operate battery beyond published voltage and current limits.





IMPORTANT













- When installing batteries, leave adequate clearance between batteries.
- When replacing batteries, use the same number and type of batteries.
- Avoid any fall or collision during the installation process.
- Do not remove the battery components. The maintenance of the battery should be carried out by a professional engineer.
- DO NOT use the battery when it became hot, bulges, deforms or leaks.
- Do not expose the Li-ion battery to heat in excess of 55°C during operation, 60°C in storage.
- The SOC is 50% when shipped from factory, it needs to be recharged in time for long time storage.
- DO NOT open or try to repair the battery when it is defective. Warranty is invalid if the battery repaired or disassembled.

SAFETY INSTRUCTIONS

Labelling Explanation - To ensure user safety during product use, relevant labeling information with appropriate symbols is provided in this manual. The following is a list of symbols that may be used in this manual, so please read it carefully.

Symbols	Description
	Signifies a low-level potential hazard. Failure to avoid it may result in minor or moderate injury to personnel.
	Indicates the presence of high voltage inside the battery module. Contact may result in an electric shock hazard.
	This is the ground protection port (PE). It should be securely grounded to ensure the safety of operating personnel.

Installation Tools – Prior to installation, prepare the following tools:

Category	Description		
General Tools	 Multimeter	 Protective gloves	 Insulated safety shoes
	 Protective clothing	 Safety goggles	 Antistatic wrist strap
Installation Tools	 Electric screwdriver	 Socket wrench	 Wire stripper
	 Phillips screwdriver (M4/M6)	 Electric drill	 Hammer

Advanced Low Voltage LiFePO4 Battery

Hollandia Power Advanced Low Voltage Li-Ion battery series are designed for the residential energy storage market which combines safe, new and reliable LiFePO4 prismatic cells with a dedicated BMS to guarantee high reliability, safety, and scalability when used with different inverters.

This document is intended for use by anyone required to install and operate Hollandia Power wall/rack type Li-ion batteries. Be sure to review this manual carefully to identify any potential safety risks before proceeding.

The owner must be familiar with all the features of this product before proceeding.

Failure to install or use this product as instructed can result in damage to the product that may not be covered under the warranty.

A. Product Introduction

The **Hollandia Lithium Module** employs a passive balancing method with a maximum balancing current of 300mA, enhancing the overall lifespan of the battery pack. It features an external communication interface supporting CAN, RS485, and dry contact methods, enabling parallel communication with up to 16 batteries. The embedded BMS effectively monitors critical parameters such as over-temperature, over-voltage, and over-current, mitigating the risk of battery damage or fire, and ensuring safety.







Advantages

- The battery utilizes Lithium Iron Phosphate (LiFePO4) as the positive electrode material, known for its excellent safety performance and an impressive cycle life of over 6,000 charge-discharge cycles.
- The system integrates a high-performance intelligent management solution that controls battery charging, discharging, floating, and hibernation, with multilevel protection for voltage, current, temperature, and other parameters to maintain optimal performance.
- The system features a comprehensive monitoring solution that tracks voltage, current, temperature, capacity, and operational status of the battery in real-time.
- Designed with intelligent capabilities, the system complies with the four remote control standards outlined by national regulations: telemetry, remote signaling,

remote control, and remote adjustment.

- An integrated intelligent balancing module ensures the consistent capacity of the battery pack during long-term use, thereby extending its overall service life.
- The control panel is equipped with status displays and alarm indicators, allowing for easy monitoring of the battery's operational status and alert conditions.
- The system includes a thermal management device, enabling reliable operation across a broad temperature range.

B. Overview of the Main Components

Sl. No	Image	Description	Quantity
1		Battery	1 Pc
2		Orange – Positive Power Cable	1Pc
3		Black – Negative Power Cable	1Pc
4		Communication Cable	1Pc
5		Wall Mounting Bracket	1Pc
6		Expansion Bolt	9Pcs

C. Product Appearance

Control Panel

LiFePO4 Battery adopts the same control panel structure as Figure 1 (Fig. 1) below.

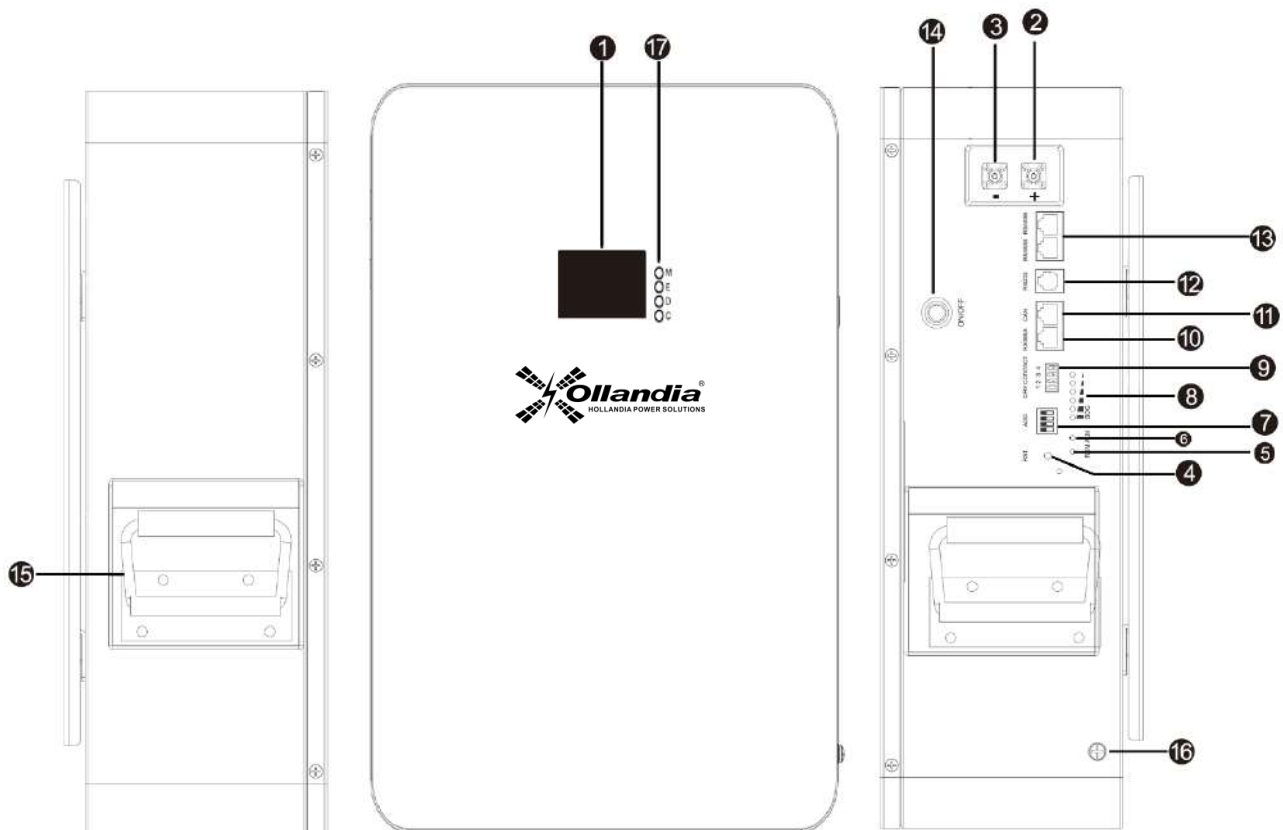

Fig. 1 – Control panel Illustration (Reference)

- | | | | |
|----------------------|---------------------|---------------------|------------------------|
| ① LCD Display Screen | ② Positive Terminal | ③ Negative Terminal | ④ RST Button |
| ⑤ RUN Lighting | ⑥ ALM Lighting | ⑦ ID Address | ⑧ SOC Display Lighting |
| ⑨ Dry Contact | ⑩ RS485A | ⑪ CAN | ⑫ RS232 |
| ⑬ RS485B | ⑭ Switch | ⑮ Metal Handle | ⑯ Ground Wire |
| ⑰ Function Buttons | | | |

Port Panel

Name	Description	Notes
Metal Casing (SPCC)	Painted Metal Casing	
Positive Terminal Port (+)	Battery Positive Output	
Negative Terminal Port (-)	Battery Negative Output	
Reset Button (RST)	Battery Reset	Briefly press and release the reset button within 1 to 3 seconds.
Operation Light (RUN)	Battery Operation Indication Lights	
Alarm Light (ALM)	Battery alarm Indicator Light	
Dry Contact	Dry Contact Communication	<ol style="list-style-type: none"> 1. Dry contact 1 – PIN 1 to PIN 2: Normally open, closed during the fault protection. 2. Dry contact 2 – PIN 3 to PIN 4: Normally open, closed during low battery alarm.
RS485A & CAN	Communication Interface	
RS232	Computer connection interface	
RS485B	Communication between batteries	The two interfaces are identical; there is no difference between them, and they can connect to other batteries regardless of their position.
Metal Handle	Battery Metal Handle	
LCD	Display screen	
Vents	Used for battery ventilation and heat dissipation	
Universal Mounting Lugs	Convenient for battery installation on the floor	
Ground Terminal Port	Battery Ground	

D. LED Indicator Description

Operating Principle

Working Principle of LiFePO₄ Energy Storage System: The battery is connected to the DC side of the inverter. Under normal grid conditions, the inverter operates to supply power to the load and simultaneously charges the battery. In the event of a power outage or when photovoltaic power is unavailable, the battery supplies uninterrupted power to the inverter, ensuring continuous operation of household electricity. Once power is restored, the battery is recharged while simultaneously

supplying power to the household loads.

Connection Structure

The connection diagram of the Low voltage LiFePO4 battery is shown in Figure 2 (Fig. 2) below.

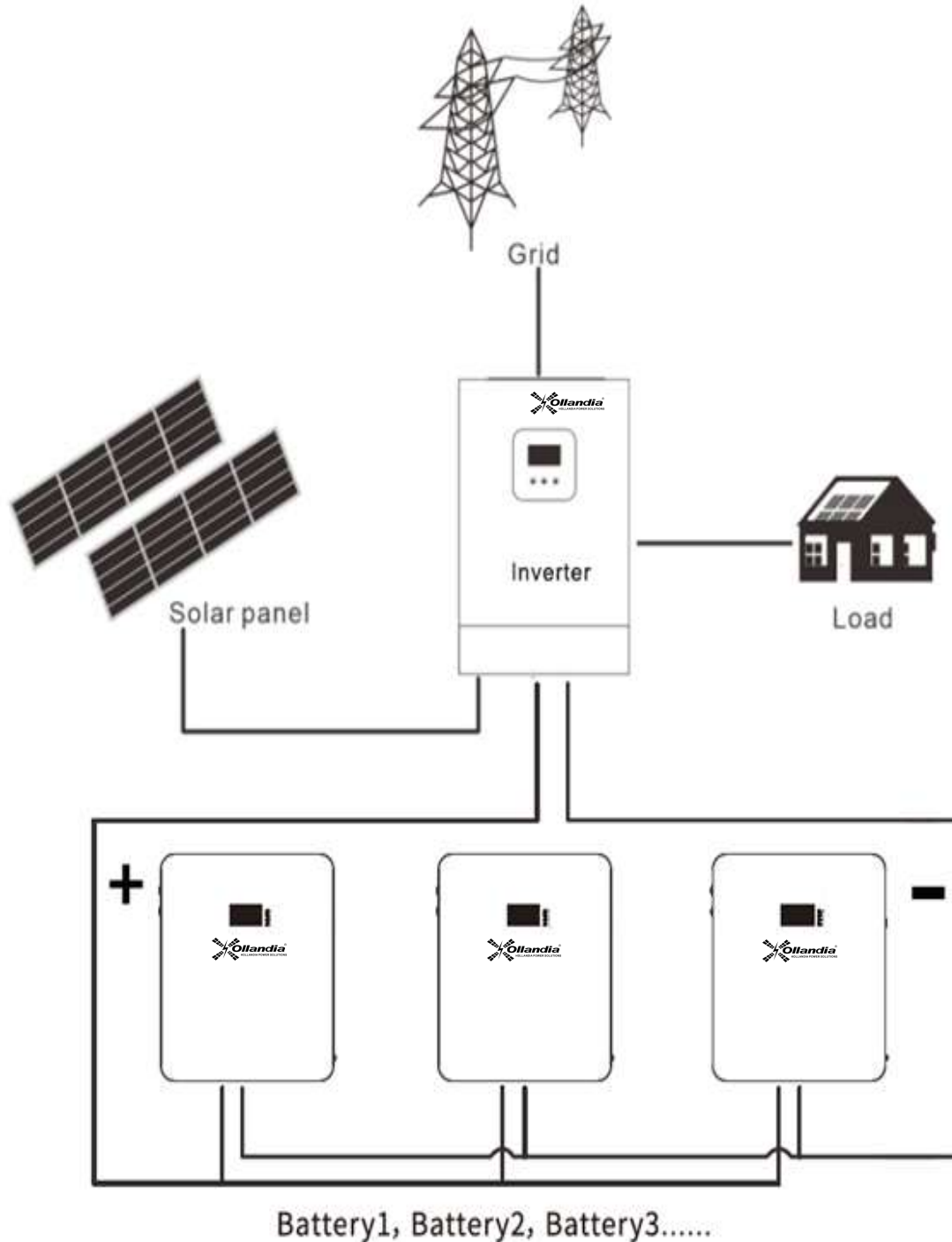

Fig. 2 - Operating Principle Diagram of the Battery System

E. Battery Installation & Wiring

Tool Preparation for Installation

Tools Required: Electric Drill, Hammer, Wrench, M8*60 Expansion Bolt, Screwdriver, Multimeter, Insulated Gloves, Ethernet Cable, Power Cables.

Installation Preparation

The installation, operation, and maintenance of the Low Voltage LiFePO₄ Battery should only be performed by trained and qualified professionals. Before installation and use, carefully read the safety precautions and operating procedures associated with this product. The installation process must adhere to the following safety guidelines and local regulations to prevent personal injury or product damage:

- Ensure that the inverter connected to the battery is part of a certified power system.
- Before installing the battery, verify that the power system is turned off and the battery is disconnected.
- All power cables must be properly insulated, and it is strictly prohibited to leave any power cables exposed.
- Confirm that both the battery and the power system are properly grounded during installation.

Installation Notes

- When beginning the installation of the battery system, the following considerations should be observed:
- Installation Space and Load Bearing: Ensure that there are sufficient fixed components to support the battery system and verify that the battery mounting bracket or cabinet is strong enough to bear the weight.
- Cable Specification: Ensure that the power supply connection cables are capable of handling the maximum current required for equipment operation.
- Project Layout: Plan the overall layout of the power equipment, batteries, and related components to ensure a logical and efficient arrangement.
- Wiring Layout: Ensure the wiring is organized and efficient, with considerations for moisture protection and corrosion prevention.

- Anti-static Precautions: The entire installation process should be conducted while wearing an anti-static wristband.
- Installation Team: The installation site should have at least two qualified personnel to operate.
- Safety Verification: Ensure the installation site is secure and meets safety requirements before proceeding with installation.

Installation Steps

- Select a suitable solid wall with a thickness greater than 150 mm.
- Refer to the mounting bracket bolt spacing and mark the hole positions on the wall.
- Drill 9 holes at the marked positions, with a depth of ≥ 80 mm.
- Insert M8 expansion bolts into the upper holes and secure with nuts.
- Attach the mounting bracket to the wall using the expansion bolts.
- With the battery held vertically, lift it to a position slightly above the mounting bracket and hang the battery onto the bracket.

Note:

- Before installing the battery, ensure that it is powered off. Additionally, shut down any equipment that will be connected to the battery.
- To prevent electric shock or injury, verify that the existing electrical and plumbing installations comply with safety standards before drilling.
- The battery is heavy; handle it with care to avoid product damage or injury to the installer.

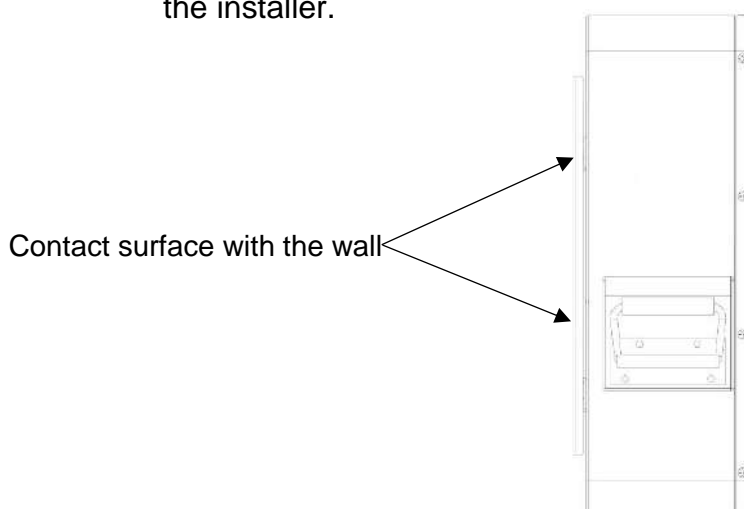

Fig. 3 – Battery with Mounting Bracket

Electrical Connection

1. Single Battery Installation Steps

Step 1: Connect the battery's positive and negative terminals to the inverter's positive and negative terminals using the power cable.

Step 2: Complete the battery grounding connection using the ground cable.

Step 3: Connect the battery's RS485A (CAN) port to the inverter's RS485 (CAN) communication port using the communication cable.

Step 4: If using a single unit, set the ADS dip switch to 1. Refer to the relevant section for dip switch configuration rules.

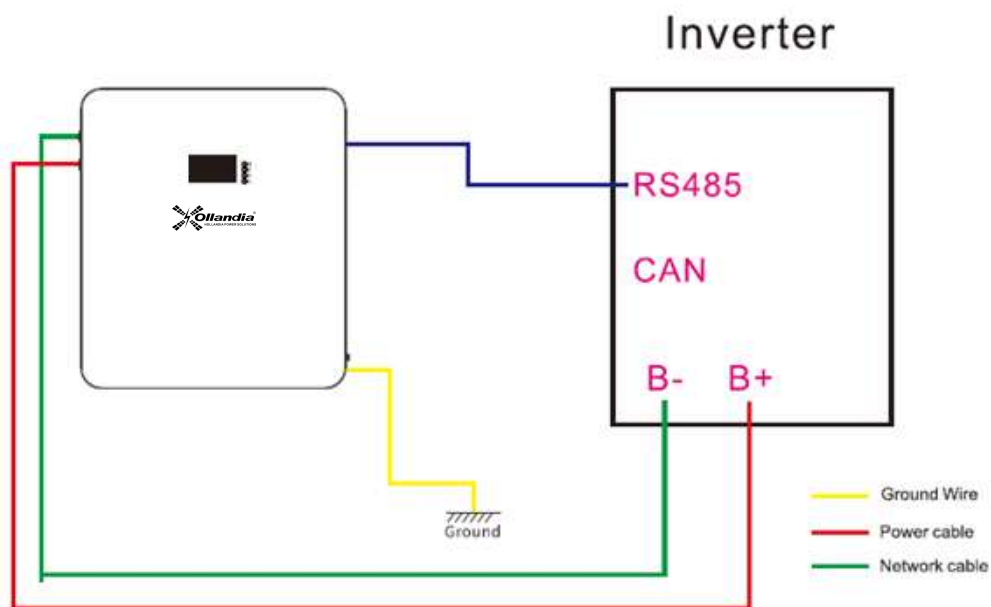

Fig. 4 – Single Battery with Inverter

2. Parallel Battery Installation Steps

Step 1: If multiple batteries are connected in parallel, manually press the low-voltage switch (ON/OFF) on each battery. Use a multimeter to verify that the voltage of all batteries is consistent. If the voltages match, turn off the batteries and proceed with cable connections, as illustrated in the schematic diagram (example: 2 batteries in parallel).

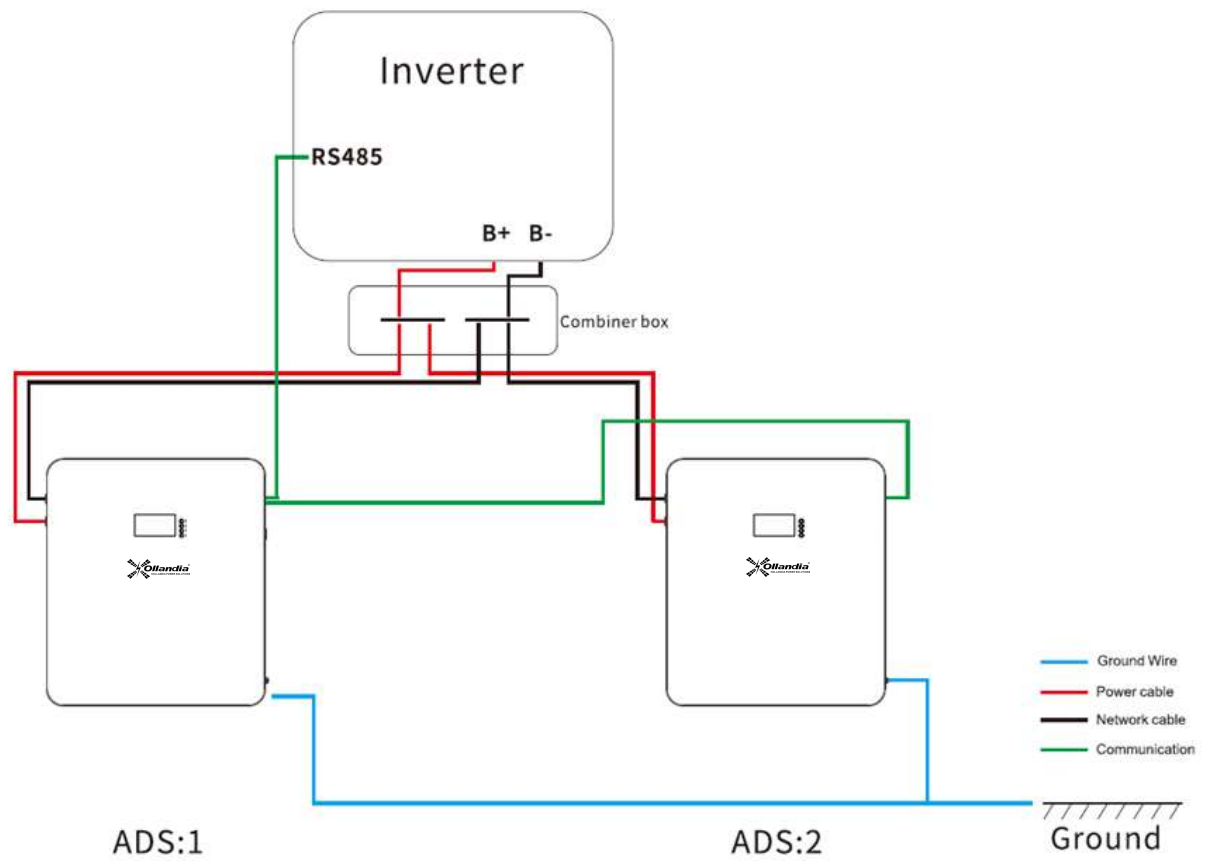

Fig. 5 – Two Batteries in Parallel with Inverter

Step 2: Connect the positive terminals of all batteries using the power cable, then connect the negative terminals using the power cable.

Step 3: Interconnect the RS485B communication interfaces of adjacent batteries using communication cables (RS485B parallel ports have identical functionality and are interchangeable).

Step 4: Connect the ground wire to the grounding point on each battery. The grounding symbol is located in the lower-left corner of the battery; attach the ground wire terminal to this point.

Step 5: Use a standard Category 6 (CAT6) cable to connect the RS485A (CAN) communication port of the battery to the RS485 (CAN) port of the inverter. (Note:

Ensure that the pin configuration of the inverter communication port matches that of the battery. Refer to the relevant section for battery-to-inverter pin definitions.)

Step 6: Connect the positive terminal (+) of the first battery to the positive input of the inverter using a power cable. Then, connect the negative terminal (-) of the last battery to the negative input of the inverter using a power cable.

Note:

- The battery directly connected to the inverter via the communication cable is designated as the host. The host dip switch must be set to 1 before powering on.
- Set the dip switches for additional batteries sequentially from 2 to 15, ensuring that no other battery is set to 1 to avoid conflicts.

F. Debugging

RS485 Port Definition

The RS485A port is used for communication between the battery and the inverter, with a default baud rate of 9600 bps.

Note: The default RS485 communication protocol for the battery is set to Hollandia (Pylontech) RS485 (V3.5) protocol. If compatibility with other inverters is required, the protocol must be changed via RS232 communication with a host computer.

PIN2/7 (White & Orange)	485-A
PIN1/8 (Orange)	485-B

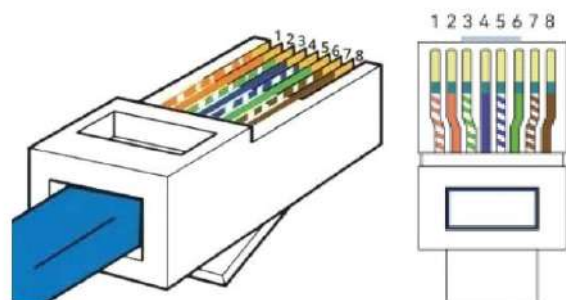

CAN Port Definition

The CAN port is used for communication between the battery and the inverter, with a default baud rate of 500Kbps.

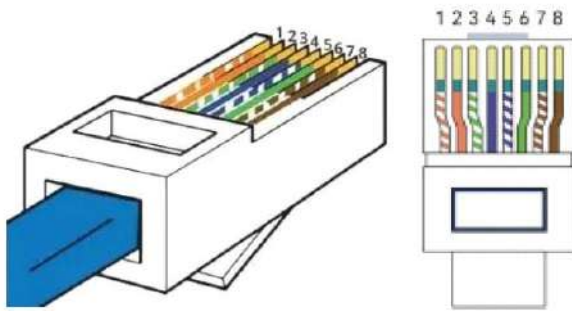

PIN4 (Blue)	CAN H
PIN5 (Blue and White)	CAN L

Note: The battery is factory set with the Pylontech CAN (V1.2) protocol by default. If compatibility with other inverters is required, the protocol must be changed via RS232 communication with a host computer.

General Note: For battery-to-inverter communication, use either RS485 or CAN, but not both simultaneously.

G. Software Operation Guide

Modifying Battery Parameters and Selecting Inverter Protocol via RS232 Using a computer.

Tools Required:

- Computer
- USB to RS232 Cable
- Monitoring Software

Operating Steps:

1. Connect the computer to the battery using a USB to RS232 cable. Plug the USB end into the computer's USB port and the other end into the battery's RS232 port.
2. Download and extract the software package on the computer.
3. Open the extracted folder and launch the application as shown below.

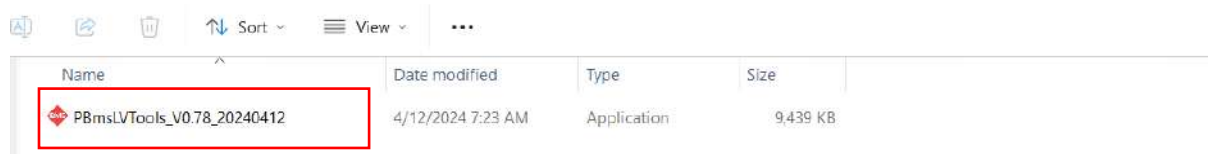

4. Double-click the icon above to open the monitoring interface, as shown below:

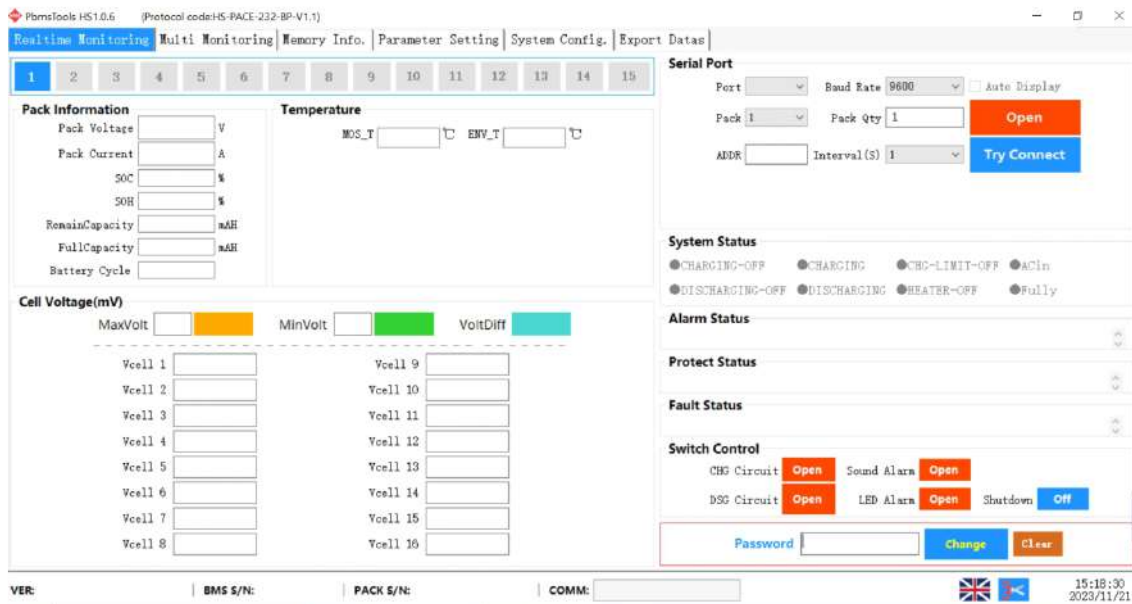

5. After entering the monitoring interface, click the top-right corner to open the serial port. Once communication with the battery is established, real-time battery information will be displayed on the left side, and the status bar in the lower right will turn green.

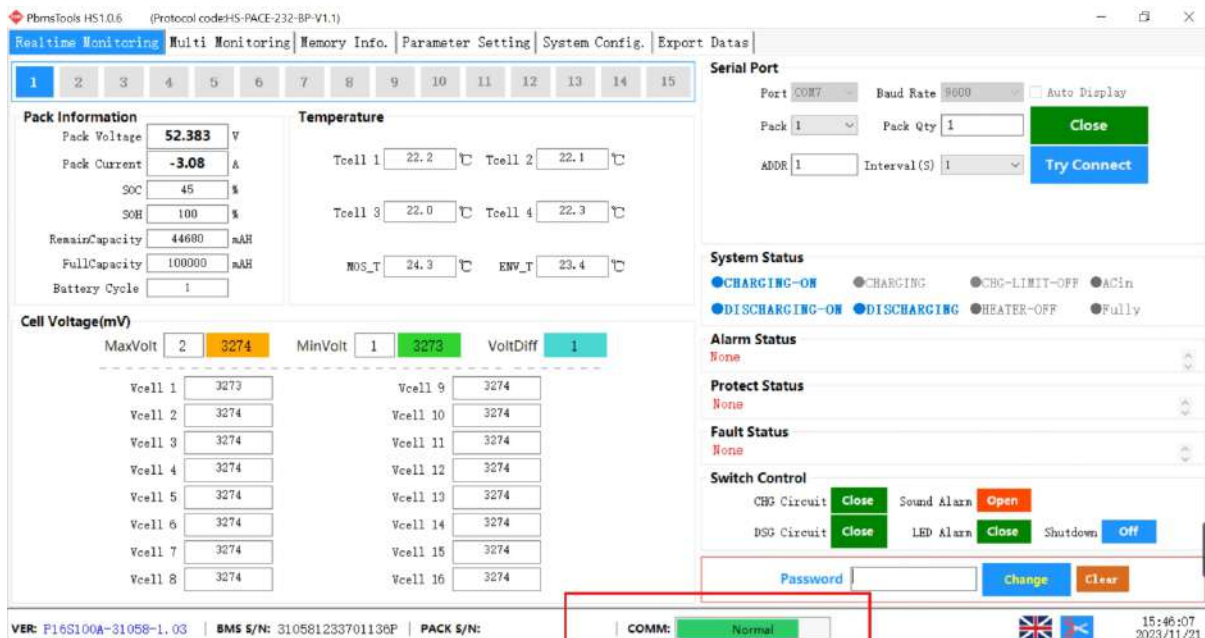

6. After successful communication, enter the password "123456" in the password status bar at the lower right. If the input is correct, the status bar will turn green.



7. Left click on "System Config." as shown below.

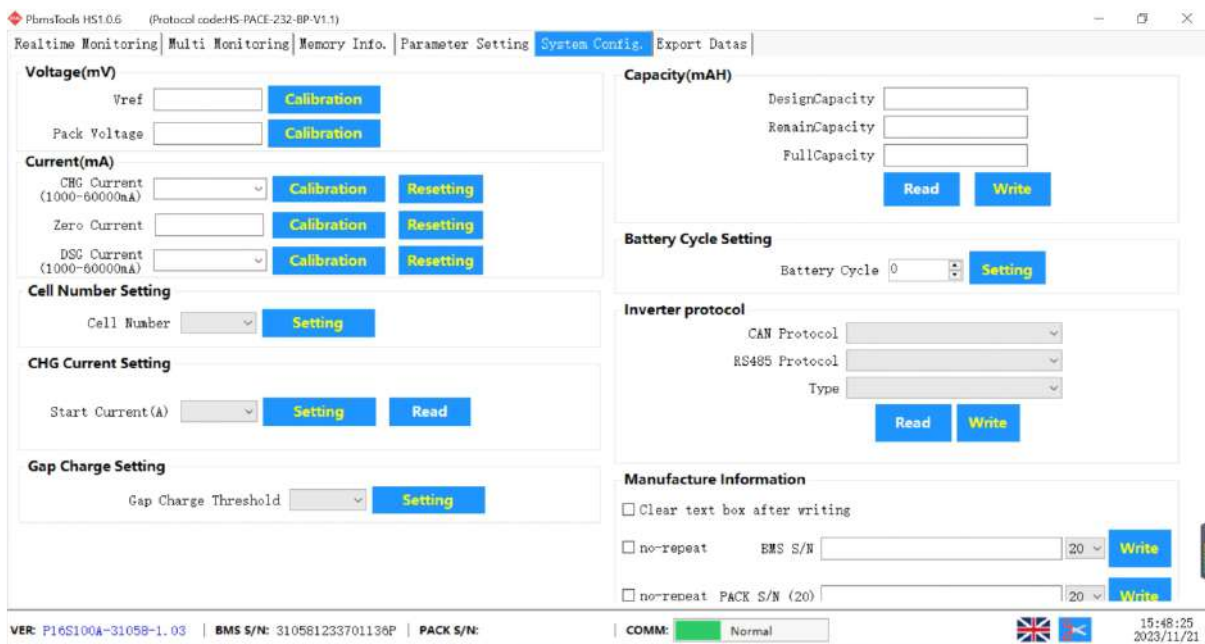

8. In the middle-right section of the display interface (Inverter Protocol), click "Read" to check if the battery matches the actual inverter brand. If it does not match, select either the CAN or RS485 protocol and choose the one that corresponds to the inverter, as shown below.

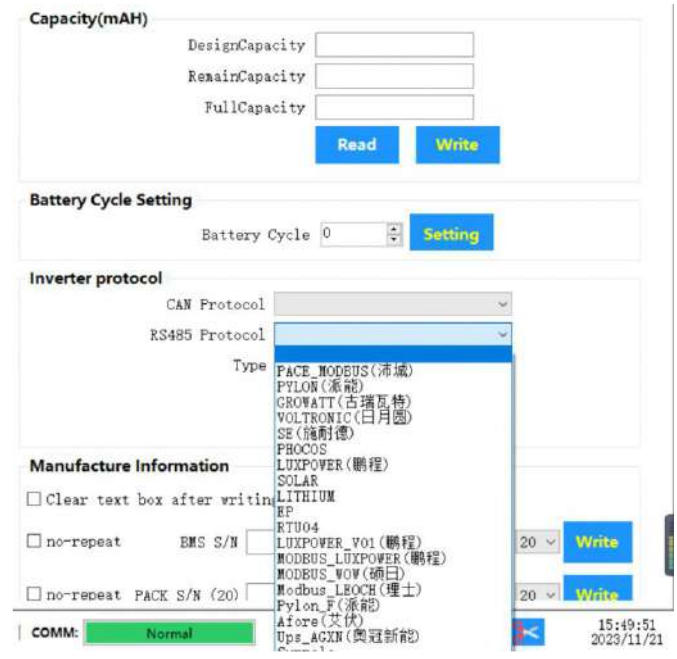
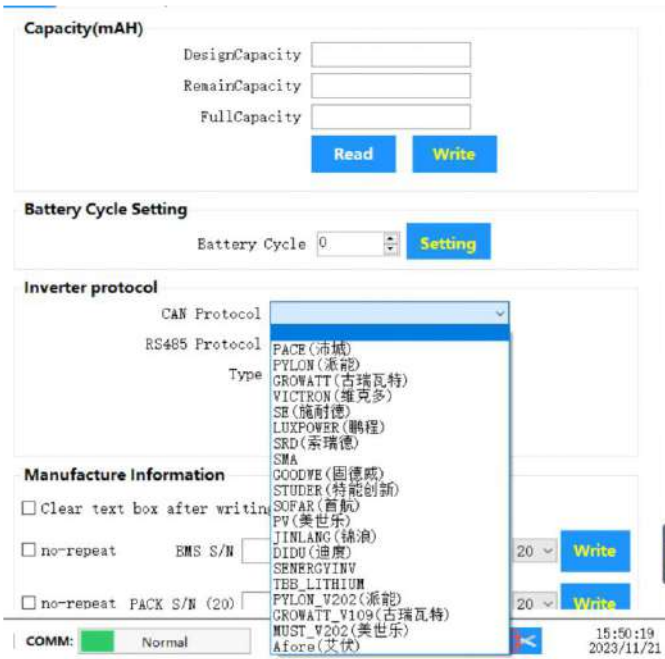

- After selecting the protocol, click the "Write" button. If the write operation fails, it indicates that the BMS does not support this inverter protocol, and a program upgrade is required. If the write operation is successful, click "Read" again to verify the selected protocol.

H. Button Display Screen Operation Guide

Protocol Selection for Button Display Screen

By selecting the appropriate communication protocol version and sending the selected version number to the BMS motherboard program, the user can change the default communication protocol between the BMS and the host computer. This option is available under the system settings menu. The menu structure is as follows:

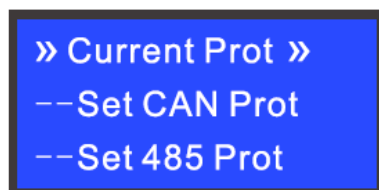

Fig. 6

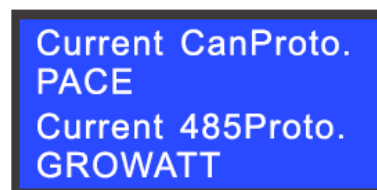

Fig. 7



Fig. 8



Fig. 9

Button Description

1. SW1-----MENU, SW2-----ENTER, SW3-----DOWN, SW4-----ESC
2. Each item begins with "" or "- -" where " " indicates the current cursor position. Press DOWN to move the cursor. If an item ends with "", it means there is no displayed content. Press ENTER to navigate to the corresponding page.
3. Press ESC to return to the previous menu. At any location, press MENU to return to the main menu.
4. In hibernation mode, press any key to activate the display.

Hibernate/ Shut Down

In the normal operating state, the system enters hibernation or shut down after one minute of inactivity. In the off/sleep state, pressing any key will activate the display.

I. Transportation

The product passes the certifications of the UN38.3 (UN38.3: Section 38.3 of the sixth Revised Edition of the Recommendations on the Transport of Dangerous Goods, Manual of Tests and Criteria) and SN/T 0370.2-2009 (Part 2: Performance Test of the Rules for the Inspection of Packaging for Exporting Dangerous Goods).

This product belongs to class 9 dangerous goods.

The SOC is 50% when shipped from our factory.

The packing case must be secured for transportation, compliant with international standards, and printed with marks such as anti-collision, Fragile and moisture prevention. Dispose of waste ESMs in strict accordance with local laws and regulations. Protect the packing case with the product from the following situations:







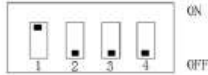
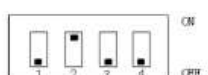
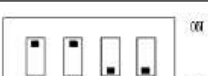
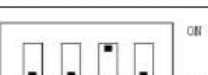

- Being dampened by rain, snows, or falling into water
- From falling or physical impact
- Being upside-down or tilted

J. Storage

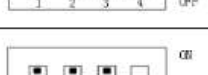
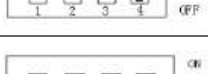

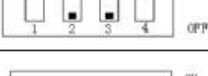
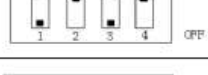

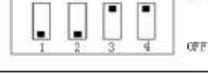
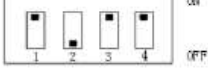







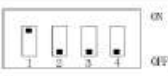

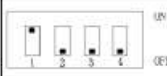

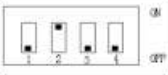
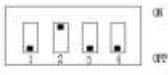
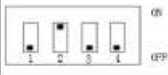



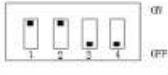
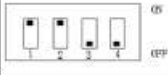

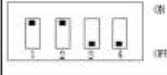

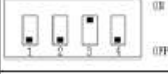

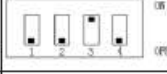
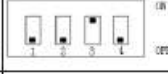
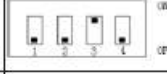



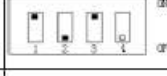
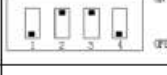
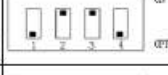
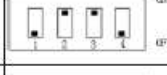
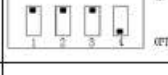
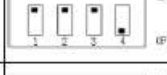
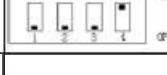
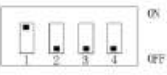
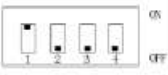
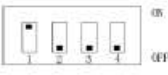
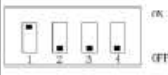
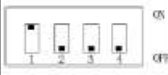
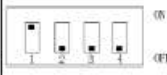



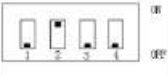

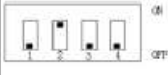

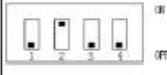

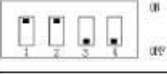
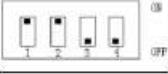
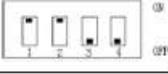

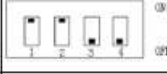
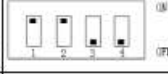
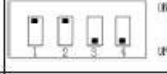
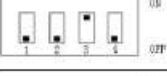
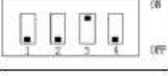
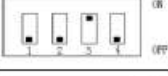
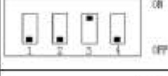
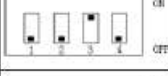

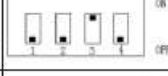
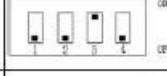

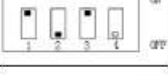
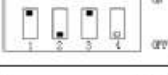

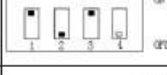
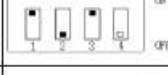
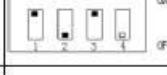
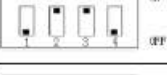

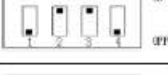
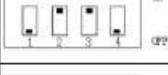

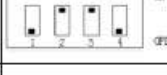

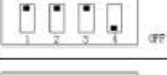
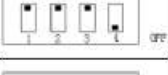
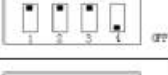
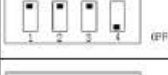
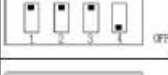
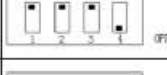
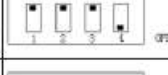
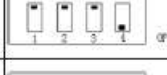

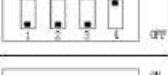
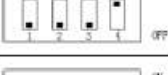
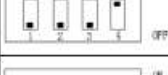
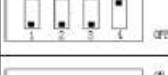

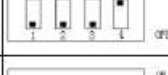
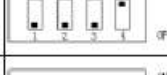
The Li-ion battery can be stored in an environment with temperatures between -40°C and +60°C and between 10% and 90% relative humidity, noncondensing.

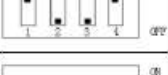

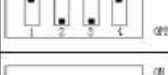

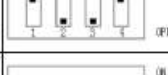
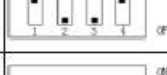
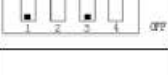
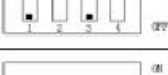
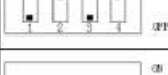
- For long storage periods at 25°C, charge the battery every 6 months.
- For temperatures above 40°C, charge the battery every quarter.
- Do not store the Li-ion battery at temperatures above 60°C.

K. ADS DIP Switch Definitions

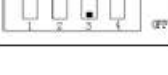
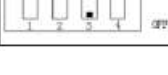
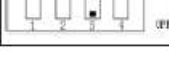
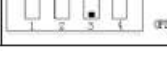
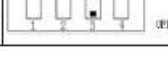
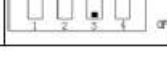
Address	DIP Switch Position				Illustration
	#1	#2	#3	#4	
0	OFF	OFF	OFF	OFF	 OFF OFF
1	ON	OFF	OFF	OFF	 ON OFF
2	OFF	ON	OFF	OFF	 ON OFF
3	ON	ON	OFF	OFF	 OFF OFF
4	OFF	OFF	ON	OFF	 ON OFF
5	ON	OFF	ON	OFF	 ON OFF
6	OFF	ON	ON	OFF	 ON OFF
7	ON	ON	ON	OFF	 ON OFF
8	OFF	OFF	OFF	ON	 ON OFF
9	ON	OFF	OFF	ON	 ON OFF
10	OFF	ON	OFF	ON	 ON OFF
11	ON	ON	OFF	ON	 ON OFF
12	OFF	OFF	ON	ON	 ON OFF
13	ON	OFF	ON	ON	 ON OFF
14	OFF	ON	ON	ON	 ON OFF
15	ON	ON	ON	ON	 ON OFF

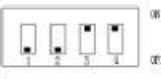
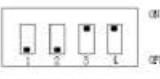
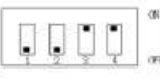
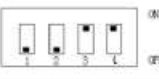
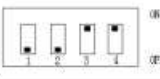
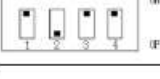
L. Battery Parallel Connection DIP Switch Diagram

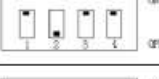
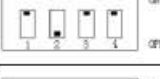
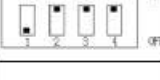
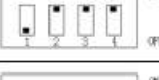
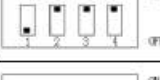
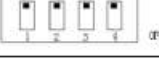
Battery 1	Battery 2	Battery 3	Battery 4	Battery 5	Battery 6	Battery 7	Battery 8
							
							
							
							
							
							
							
							
Battery 9	Battery 10	Battery 11	Battery 12	Battery 13	Battery 14	Battery 15	Battery 16
							
							
							
							
							
							
							
							
							
							
							

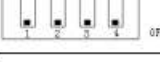











M.Power – On Sequence

After connecting the inverter, battery, and mains power, start each battery one by one, then turn on the inverter. Once the batteries are powered on, check if communication between the inverter and battery is functioning properly. Successful communication is confirmed if the battery data is correctly uploaded to the inverter.

N. Common Issues & Solutions

Sl. No	Fault Symptoms	Cause Analysis	Solutions
1	No DC Output	Battery Voltage Too Low, Protection Triggered	Startup After Charging Activation
2	Short Power Supply Duration	Insufficient Battery Capacity or Failure to Reach Full Charge	Confirm Maintenance or Replace the Battery
3	Battery Fails to Reach Full Charge	DC Voltage Output from Power System is Lower than the Minimum Charging Voltage	Adjust the Device's DC Output Voltage to the Suitable Charging Voltage for the Battery
4	Unstable Battery Output Voltage with Significant Fluctuations	Interference with the Management System Operation	Restart the System
5	Temperature Monitoring Too Low	Damage to Temperature-Sensing Probe	Replace the collection line with a temperature-sensing probe
6	Charging Failure	Single Cell Protection Activated After Full Battery Charge	Disable Discharge Protection
7	Abnormal MOS Temperature	Damaged MOS Tube	Replace BMS
8	Discharge Overcurrent Protection Activated	Inverter Power Exceeds Limit	Match the number of batteries to the inverter power rating.

O. Major Inverters BMS Port (RS485 and CAN)

Inverter Brand	Logo	Type	Inverter Communication Pin	Battery Communication Pin	Remarks
Hollandia Power		RS485	PIN7: RS485A PIN8: RS485B	PIN2/7: RS485A PIN1/8: RS485B	<ol style="list-style-type: none"> 1. Default Battery Protocol Matching 2. Inverter setting Option Li2
Voltronic Power		RS485	PIN5: RS485A PIN3: RS485B	PIN2/7: RS485A PIN1/8: RS485B	<ol style="list-style-type: none"> 1. Default Battery Protocol Match 2. Custom Network Cable
VICTRON		CAN	PIN7: CANH PIN8: CANL	PIN4: CANH PIN5: CANL	<ol style="list-style-type: none"> 1. Change the Battery Protocol 2. Custom Network Cable
Growatt		RS485	PIN2: RS485A PIN1: RS485B	PIN2/7: RS485A PIN1/8: RS485B	<ol style="list-style-type: none"> 1. Default Battery Protocol Match 2. Inverter setting Option 2
		CAN	PIN4: CANH PIN5: CANL	PIN4: CANH PIN5: CANL	
PYLONTECH		RS485	PIN7: RS485A PIN8: RS485B	PIN2/7: RS485A PIN1/8: RS485B	Default Battery Protocol Matching
GOODWE		CAN	PIN4: CANH PIN5: CANL	PIN4: CANH PIN5: CANL	Default Battery Protocol Matching
LUXPOWER		RS485	PIN2: RS485A PIN1: RS485B	PIN2/7: RS485A PIN1/8: RS485B	<ol style="list-style-type: none"> 1. Change the Battery Protocol 2. Custom Network Cable
SOFAR		CAN	PIN1: CANH PIN2: CANL	PIN4: CANH PIN5: CANL	<ol style="list-style-type: none"> 1. Change the Battery Protocol 2. Custom Network Cable
SRNE		RS485	PIN7: RS485A PIN8: RS485B	PIN2/7: RS485A PIN1/8: RS485B	<ol style="list-style-type: none"> 1. Default Battery Protocol Match 2. Inverter setting PYL
Deye		RS485	PIN7: RS485A PIN8: RS485B	PIN2/7: RS485A PIN1/8: RS485B	Default Battery Protocol Matching
		CAN	PIN4: CANH PIN5: CANL	PIN4: CANH PIN5: CANL	
MEGAREVO		CAN	PIN4: CANH PIN5: CANL	PIN4: CANH PIN5: CANL	Default Battery Protocol Matching
MUST		CAN	PIN6: CANH PIN5: CANL	PIN4: CANH PIN5: CANL	<ol style="list-style-type: none"> 1. Change the Battery Protocol 2. Custom Network Cable
SMA		CAN	PIN4: CANH PIN5: CANL	PIN4: CANH PIN5: CANL	<ol style="list-style-type: none"> 1. Change the Battery Protocol 2. Custom Network Cable

P. Maintenance

1. **Avoid Submerging the Battery in Water:** Store the battery in a cool, dry environment when not in use to maintain optimal performance.
2. **Do Not Expose to Fire or Extreme Heat:** Never expose the battery to high temperatures or fire, as this could lead to explosions or other hazards.
3. **Avoid Reversing Polarity:** Do not invert the battery's positive and negative terminals. Never connect the battery directly to a power outlet or allow short circuits between the terminals.
4. **Do Not Mix Batteries:** Never mix batteries from different manufacturers, types, or ages to prevent safety issues and performance degradation.
5. **Inspect for Damage Before Use:** Do not use batteries that show signs of heating, swelling, deformation, or leakage during charging or discharging.
6. **Avoid Physical Damage:** Do not puncture the battery with nails or sharp objects, or subject it to crushing, stepping on, hitting, or impact.
7. **No Disassembly:** Never disassemble or dismantle the battery and its components. Unauthorized disassembly or repairs will void any warranty and Ollandia will not be liable for any resulting damages.
8. **Pre-Use Inspection:** Each battery undergoes strict inspection prior to shipment. If signs of heating, swelling, or unusual odors are detected, discontinue use and return the battery to our showroom.
9. **Long-Term Storage:** For optimal battery performance during long-term storage, perform a charge-discharge cycle every three months. Maintain a storage charge between 40% and 60%.
10. **Adhere to Temperature Specifications:** Use the battery only within the temperature range specified in the product specification to ensure proper function.
11. **Follow Power-Up Sequences:** Always adhere to the specified power-up sequences for both the battery and the inverter to avoid operational issues.
12. **Load Power Limitations:** Ensure that the battery load does not exceed the maximum continuous discharge current, which is 100A for the 5kWh Powerwall.
13. **Periodic Manual Charging for Long-Term Storage:** If the battery remains unused for more than three months, perform periodic manual charging to prevent deep discharge.

Note: In case of specific technical issues or situations not mentioned above, please contact technical support of Hollandia promptly.

GENERAL NOTICE: The information contained in this manual is the property of Hollandia Power Solutions Inc. and is subject to change without notice. Hollandia reserves the right to make changes in the design of its products or components as progress in engineering and manufacturing may warrant. It is the customer's responsibility to satisfy itself as to whether the information contained herein is adequate and sufficient for a user's particular use. It is the further responsibility of each user to ensure that all applications of Hollandia's products are appropriate and safe based on conditions anticipated or encountered during use.

This document does not create any additional obligation for Hollandia and does not constitute additional warranties and representations.

Copyright © Hollandia Power Solutions Inc.